



TDA7396

45W/2Ω BRIDGE CAR RADIO AMPLIFIER WITH DIAGNOSTIC FACILITY

- HIGH POWER CAPABILITY:
 - 65W/2Ω MAX
 - 60W/2Ω EIAJ
 - 45W/2Ω @ $V_s = 14.4V$, $f = 1KHz$, $d = 10\%$
- DIFFERENTIAL INPUTS (EITHER SINGLE ENDED OR DIFFERENTIAL INPUT SIGNALS ARE ACCEPTED)
- MINIMUM EXTERNAL COMPONENT COUNT:
 - NO BOOTSTRAP CAPACITORS
 - NO BOUCHEROT CELLS
 - INTERNALLY FIXED GAIN (26dB)
 - NO SVR CAPACITOR
- ST.-BY FUNCTION (CMOS COMPATIBLE)
- AUTOMATIC MUTE DURING TURN-ON/OFF
- AUTOMUTE AT MINIMUM SUPPLY VOLTAGE DETECTION
- SYNCHRONIZING PIN FOR SIMULTANEOUS TURN-ON IN MULTI-DEVICE APPLICATIONS
- NO AUDIBLE POP DURING MUTE AND ST-BY OPERATIONS

Diagnostic Facilities:

- CLIPPING DETECTOR

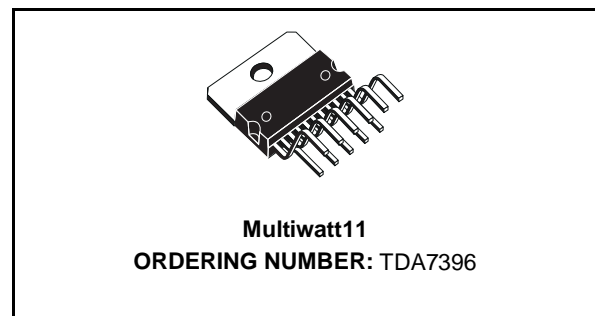

- SHORT CIRCUIT
- OPEN LOAD
- THERMAL SHUTDOWN

PROTECTIONS:

- SHORT CIRCUIT (TO GND, TO V_s , ACROSS THE LOAD)
- VERY INDUCTIVE LOADS
- CHIP OVER-TEMPERATURE
- LOAD DUMP
- OPEN GND
- ESD

Figure 1: Test And Application Circuit

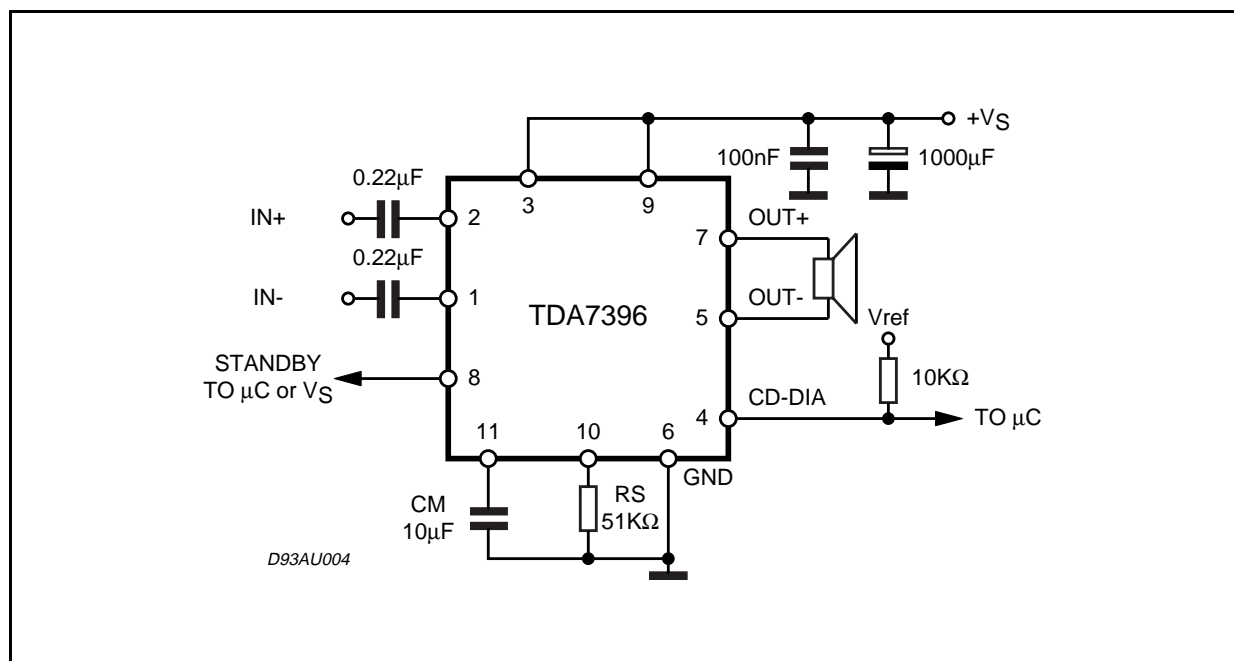

TDA7396

DESCRIPTION

The TDA7396 is a BRIDGE class AB audio power amplifier especially intended for car radio High Power applications.

The 2Ω power capability together with the possibility to operate either in DIFFERENTIAL INPUT MODE or SINGLE ENDED INPUT MODE makes it suitable for boosters and high end car radio ap-

plications.

The exclusive fully complementary output stage and the internally fixed gain configuration drop the external component count.

The on board clipping detector allows easy implementation of gain compression systems.

The diagnostics facility allows to detect any mistakes during car radio set assembly and wiring in the car.

Figure 2: Block Diagram

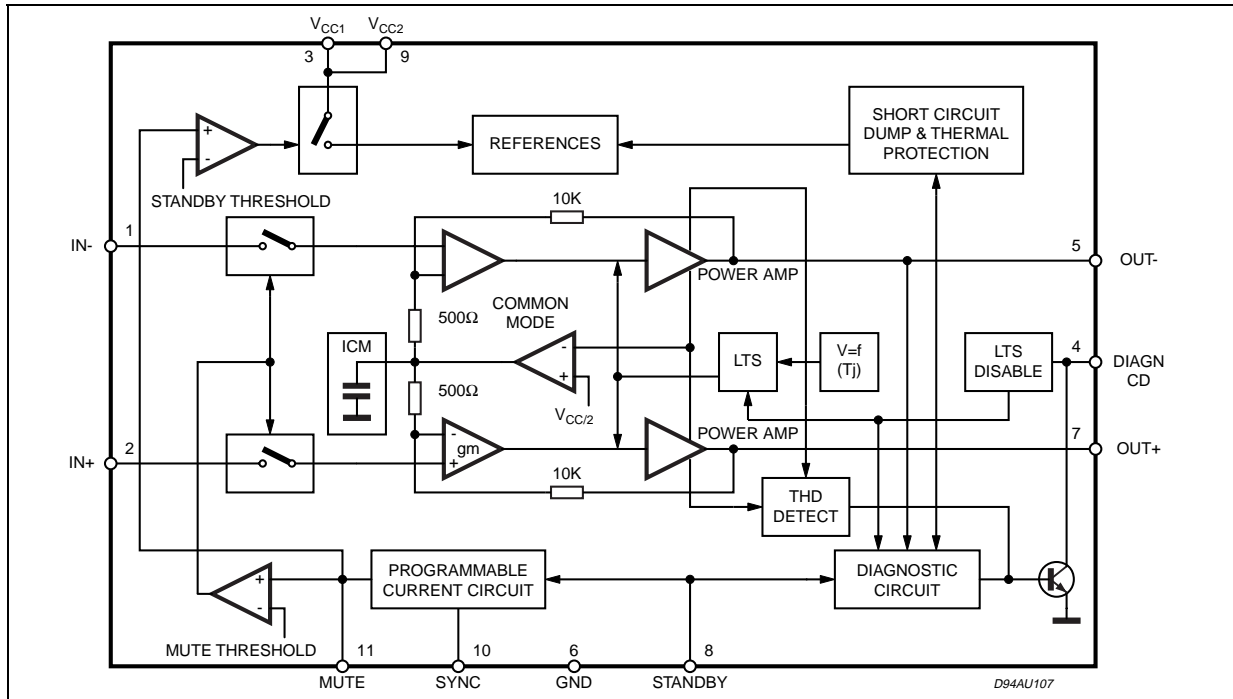

PIN CONNECTION (Top view)

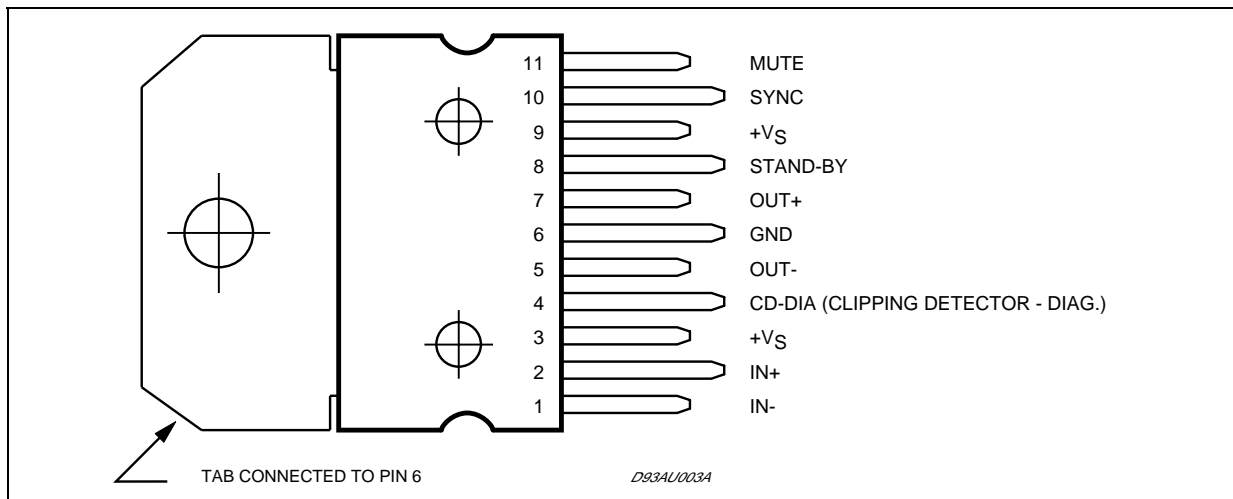

THERMAL DATA

Symbol	Description	Value	Unit
$R_{th\ j-case}$	Thermal Resistance Junction-case	Max 1.5	°C/W

ABSOLUTE MAXIMUM RATINGS

Symbol	Parameter	Value	Unit
V _S	DC Supply Voltage	28	V
V _{OP}	Operating Supply Voltage	18	V
V _{PEAK}	Peak Supply Voltage (t = 50ms)	50	V
I _O	Output Peak Current repetitive (f > 10Hz)	6	A
	Output Peak Current non repetitive	7	A
P _{tot}	Power Dissipation (T _{CASE} = 85°C)	43	W
T _{stg} , T _j	Storage and Junction-Case	-40 to 150	°C

ELECTRICAL CHARACTERISTICS (V_S = 14.4V; R_L = 2Ω, f = 1KHz, T_{amb} = 25°C, unless otherwise specified)

Symbol	Parameter	Test Condition	Min.	Typ.	Max.	Unit
V _S	Supply Voltage Range		8		18	V
I _q	Total Quiescent Current			100		mA
V _{OS}	Output Offset Voltage				150	mV
I _{SB}	ST-BY Current	V _{ST-BY} = 1.5V			100	μA
I _{SBin}	ST-BY Input Bias Current	V _{ST-BY} = 5V			10	μA
V _{SBon}	ST-BY On Threshold Voltage				1.5	V
V _{SBoff}	ST-BY Off threshold Voltage		3.5			V
ATT _{ST-BY}	ST-BY Attenuation			90		dB
R _{EXT} /R _S	Mute Resistor Ratio for External Mute Control	(see Application Circuit of fig. 4)	0.63		0.69	V
I _{M in}	Mute Input Bias Current	V _{MUTE} = 5V			10	μA
A _M	Mute Attenuation			90		dB
P _O	RMS Output Power	d = 10% d = 1% d = 10%; R _L = 4Ω		45 35 27		W W W
	EIAJ Output Power	V _S = 13.7V		60		W
d	Distortion	P _O = 0.1 to 20W P _O = 0.1 to 15W; R _L = 4Ω		0.06 0.03		% %
G _V	Voltage Gain		25	26	27	dB
f _H	High Frequency rolloff	P _O = 1W; -3dB	75			KHz
R _{IN}	Input Impedance	Differential		60		KΩ
		Single Ended		55		KΩ
E _{IN}	Input Noise Voltage	R _g = 0Ω ; f = 22Hz to 22KHz		4		μV
CMRR	Input Common Mode Rejection	f = 1KHz; V _{IN} = 1Vrms		70		dB
SVR	Supply Voltage Rejection	R _g = 0Ω; V _r = 1Vrms		60		dB
CDL	Clipping Detection Level			0.5		%
T _{sd}	Absolute Thermal Shutdown Junction Temperature			160		dB

FUNCTIONAL DESCRIPTION

Pin	Function	Description
1, 2	INPUTS	The input stage is a high impedance differential type also capable of operation in single ended mode with one input capacitively coupled to the signal GND. the impedance seen by the inverting and non inverting input pins must be matched.
4	CD - DIA	The TDA7396 is equipped with a diagnostics circuitry able to detect the following events: - Clipping in the Output Signal - Thermal Shutdown - Open Load (before turn-on) - Shorted Output: to GND, to Vs, across the load (after turn-on) The CD-DIA(open collector) pin gives out the diagnostics signal (low during clipping or output fault condition). The device does not work as long as the faulty condition holds; the normal operation is automatically restored after the fault removal.
5, 7	OUTPUTS	The output stage is a bridge type able to drive loads as high as 2Ω. It consists of two class AB fully complementary PNP/NPN stages fully protected. A rail to rail output voltage swing is achieved with no need of bootstrap capacitors. No external compensation is necessary.
8	STAND-BY	The device features a ST-BY function which shuts down all the internal bias supplies when the ST-BY input is low. In ST-BY mode the amplifier sinks a small current (in the range of few μA). When the ST-BY pin is high the IC becomes fully operational.
10	SYNC	A resistor (R _S) has to be connect between pin 10 and GND in order to program the current that flows into C _M capacitor (pin 11). The values of C _M and R _S determine the time required to bias the amplifier.
11	MUTE	a) The pin will have a capacitor (C _M) tied to GND to set the MUTE/STAND-BY time. An automatic Mute during turn on/off is provided to prevent noisy transients b) If a independent Mute function is needed, an external transistor circuit (see fig. 4) may be connected to this pin; 1% precision resistors have to be used for R _{EXT} / R _S in to order to reach the fixed limits $0.63 \leq R_{EXT} / R_S \leq 0.69$

Figure 3: Application Circuit with External Mute Control

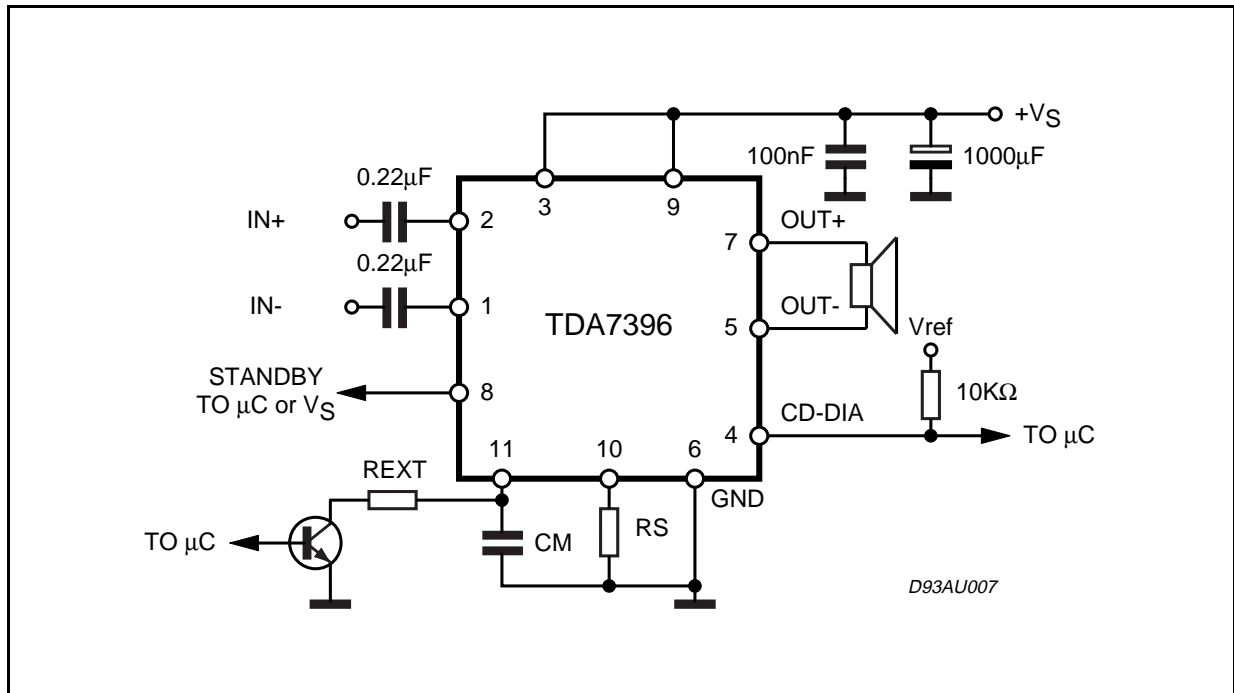

Figure 4: Quiescent Current vs Supply Voltage

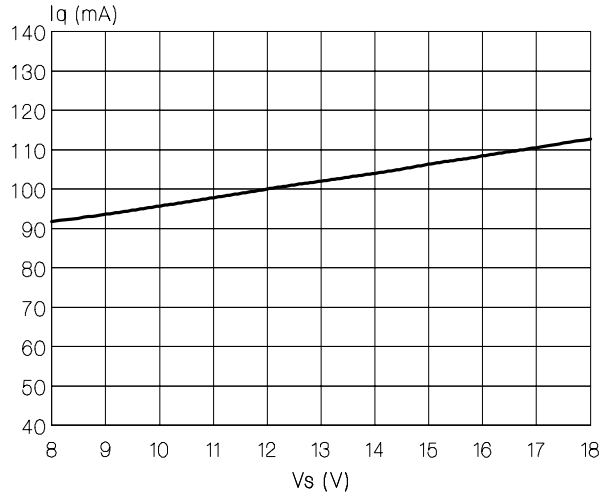

Figure 5: EIAJ power vs Supply Voltage

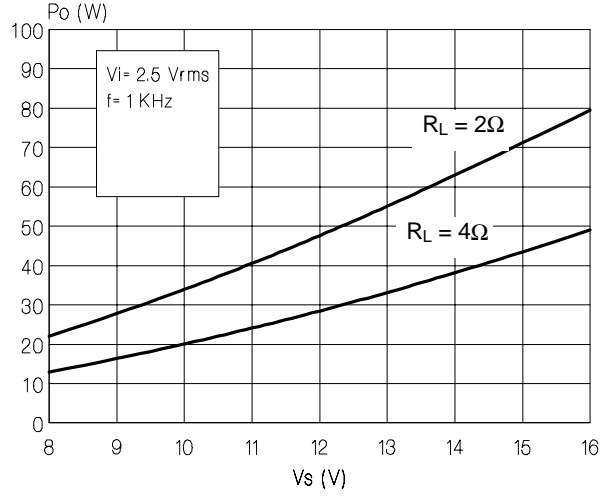

Figure 6: Output Power vs Supply Voltage (RL = 2Ω)

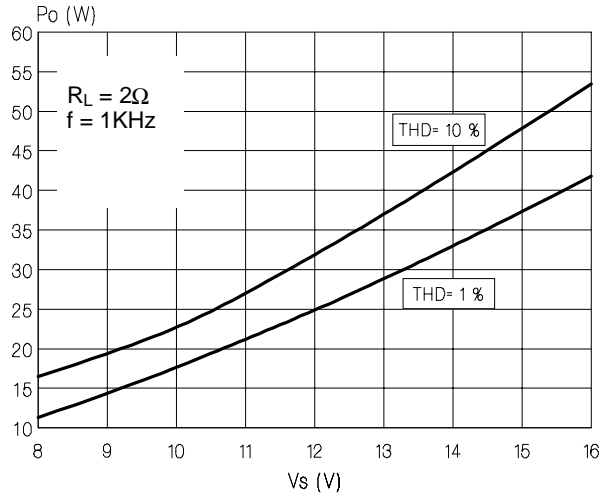

Figure 7: Distortion vs Frequency (RL = 2Ω)

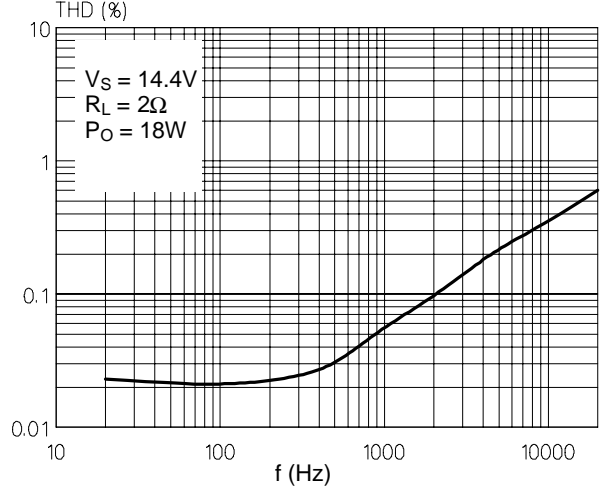

Figure 8: Output Power vs Supply Voltage (RL = 4Ω)

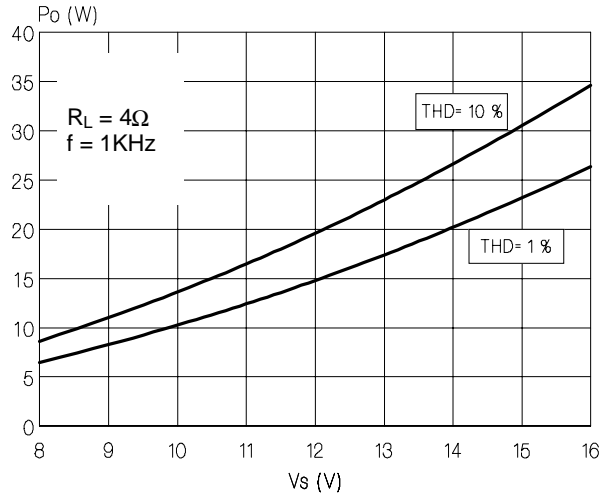

Figure 9: Distortion vs Frequency (RL = 4Ω)

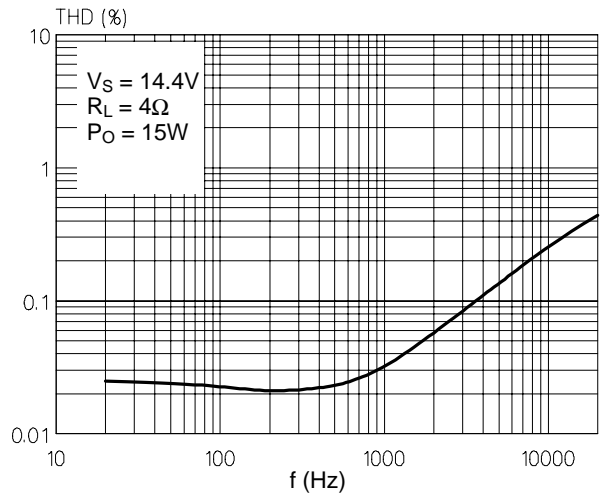

Figure 10: Supply Voltage Rejection vs Frequency

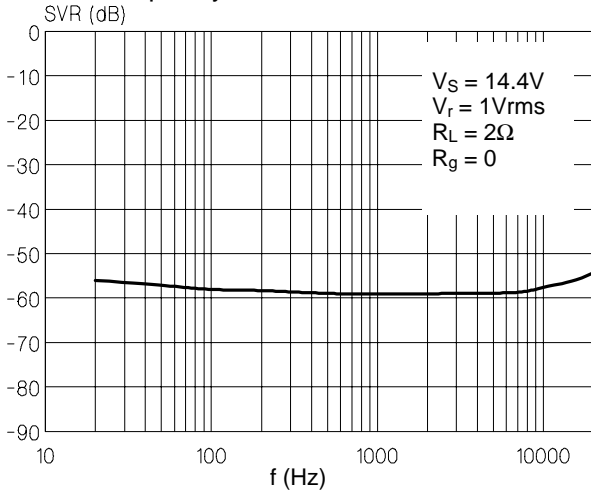

Figure 11: Common Mode Rejection vs. Frequency

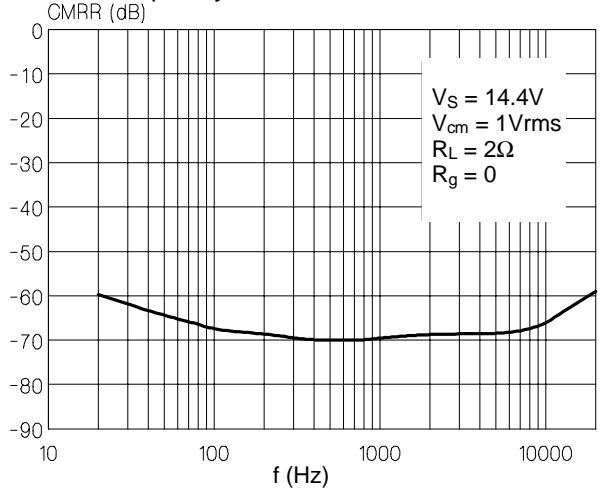

Figure 12: Total Power Dissipation & Efficiency vs. Output Power ($R_L = 2\Omega$)

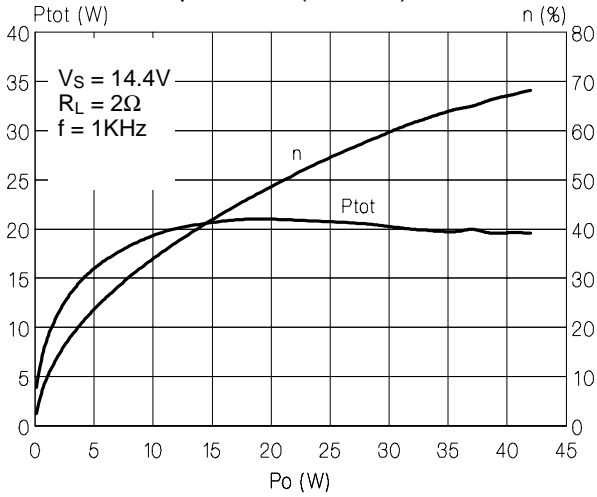

Figure 13: Total Power Dissipation & Efficiency vs. Output Power ($R_L = 4\Omega$)

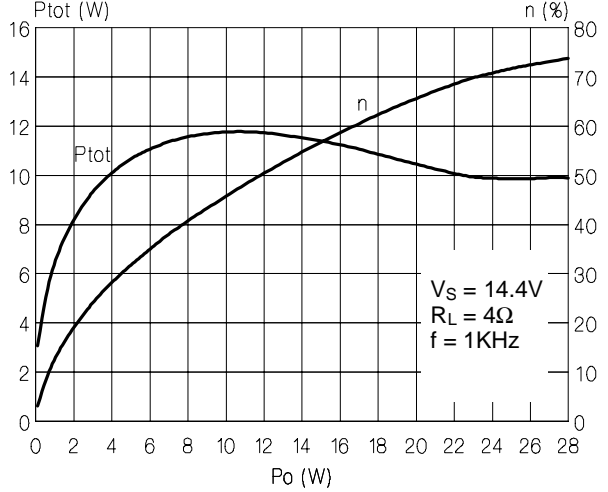

Figure 14: Application Circuit

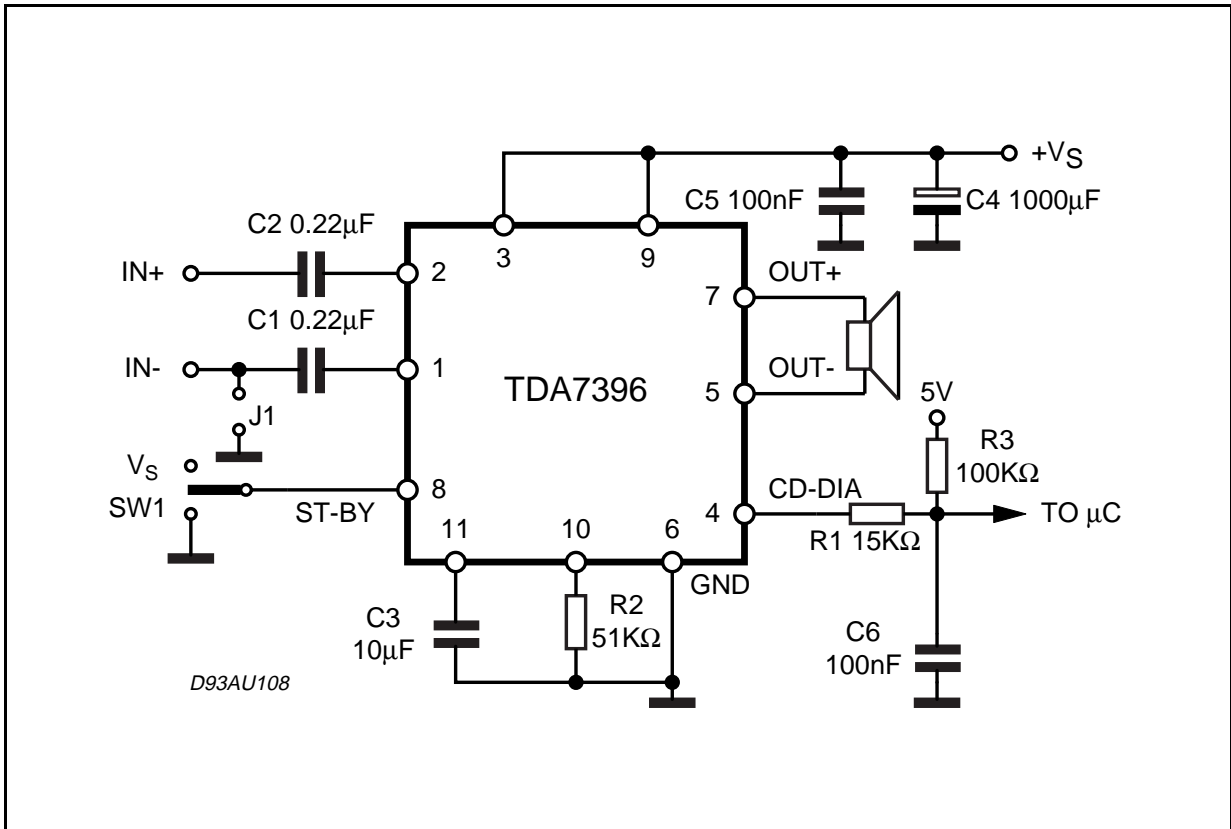
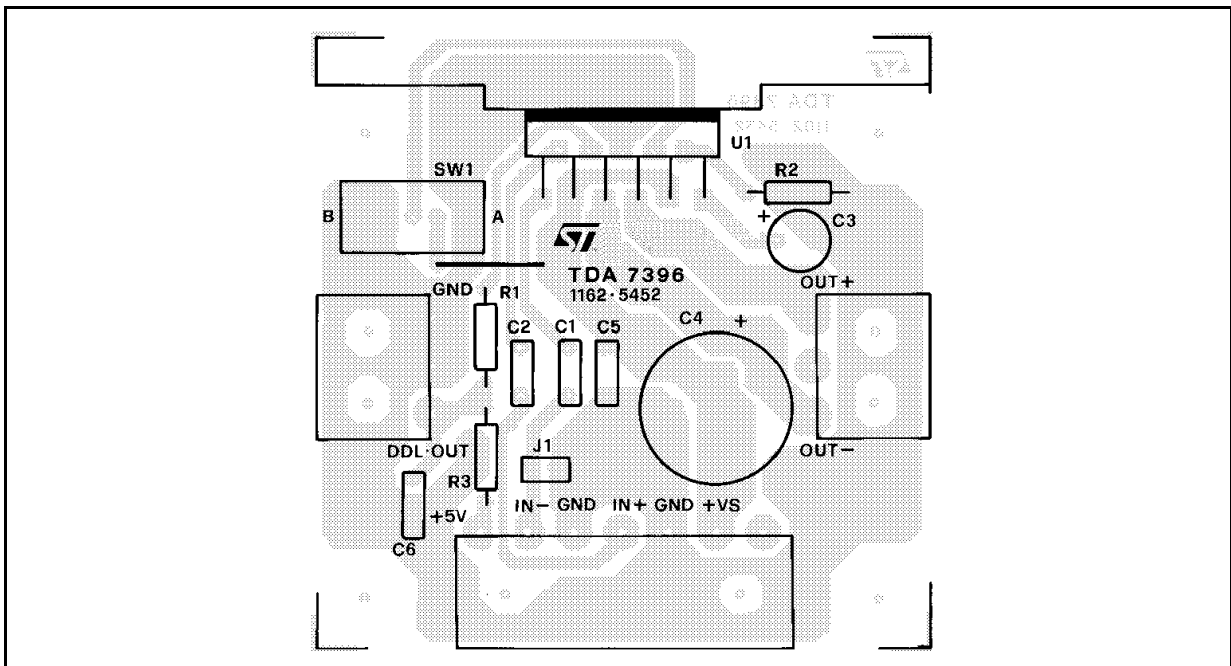

Figure 15: P.C. Board and Component Layout (1:1 scale)



CLIPPING DETECTION & DIAGNOSTICS

(see fig. 16)

An active pull-down circuit is provided to signal out the occurrence of any of the conditions described later. In order to use this function, the CD-DIA pin (#4) has to be resistively connected to a positive voltage reference (between 5V and Vs).

A) Clipping Detection

Current is sunk whenever the output clipping distortion level reaches a fixed 0.5% threshold; this function allows gain compression facility when the amplifier is overdriven.

B) Output Fault Diagnostics

Current is sunk as soon as one of the following output faults is recognized:

- short-circuit to GND
- short-circuit to Vs
- short-circuit across the load (after turn-on)
- open load (before turn-on)

The diagnostics signal remains steadily on until the fault is removed.

All the output fault conditions (listed above) can be distinguished from the clipping detection (A) because of their different time duration.

THERMAL WARNING (see fig. 17)

Thermal protection has been implemented in accordance to a new principle involving different steps:

- 1) Thermal foldback (**Linear Thermal Shutdown**)
- 2) Shutdown with soft restart (**Absolute Thermal Shutdown**)

As long as the junction temperature remains below the preset threshold (140°C) the IC delivers the full power. Once the threshold has been reached, a thermal foldback starts limiting the output signal level; the output power is then reduced, thus decreasing also the temperature without output signal interruption (LTS). Supposing the thermal foldback does not reduce the junction temperature to a safe level, a complete shutdown will occur at 160°C (ATS).

Soft restart avoids large voltage disturbance across the loudspeaker, due to the presence of high input signals when the IC comes out of thermal shutdown.

Current is sunk from the CD-DIA pin (#4) when the thermal protection is acting. The voltage at pin #4 bounces back and forth (depending on the amplifier input signal magnitude) during the linear thermal intervention (LTS) and stays low (sinking current) after the amplifier has been eventually shut-down (Absolute Thermal Shutdown)

Figure 16: Clipping Detection & Diagnostics Waveforms

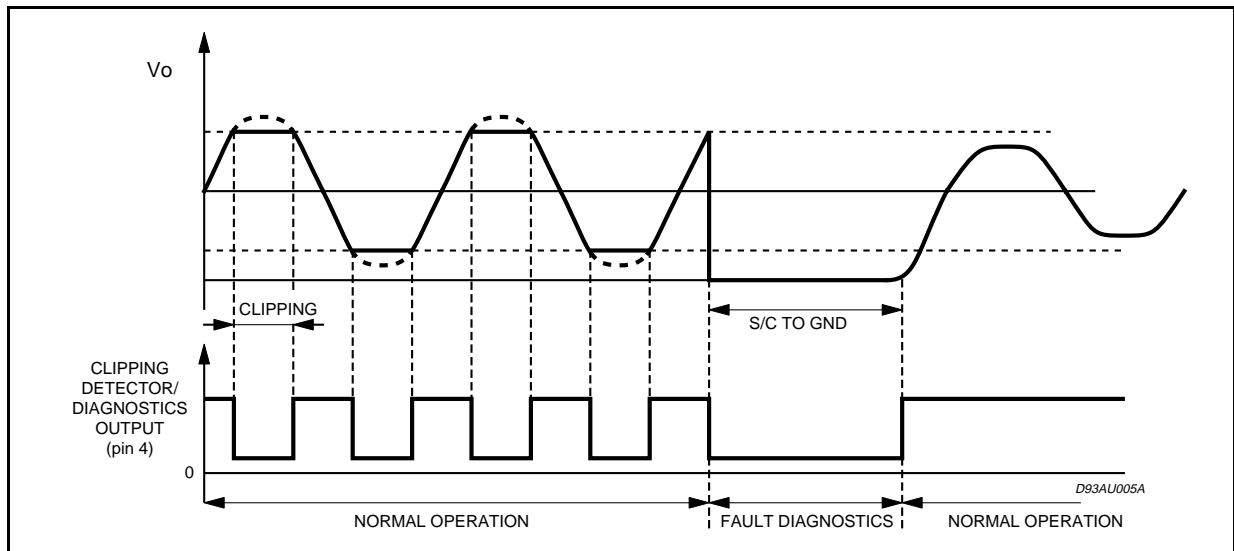
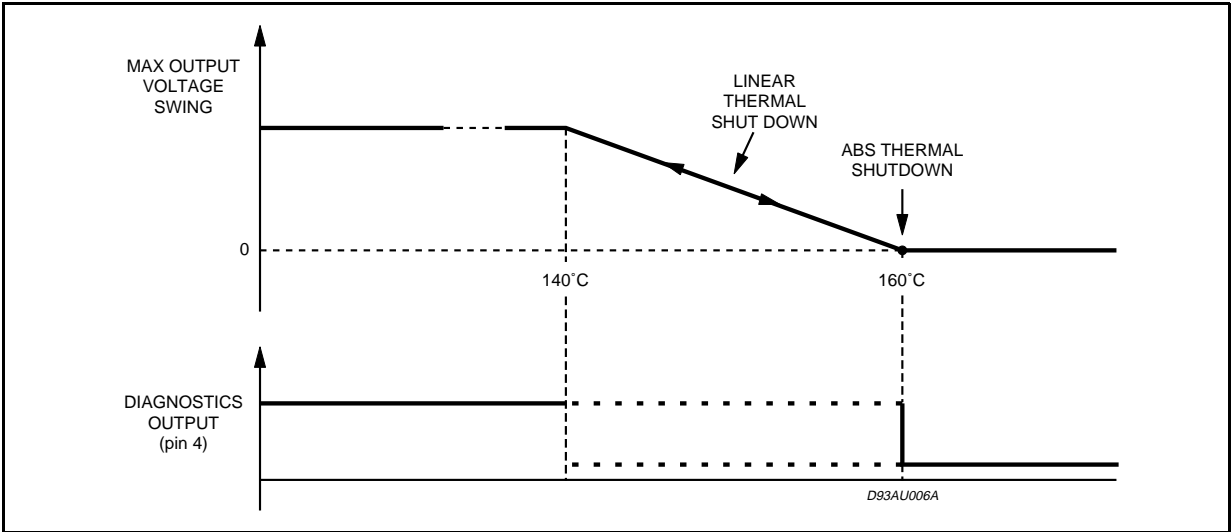
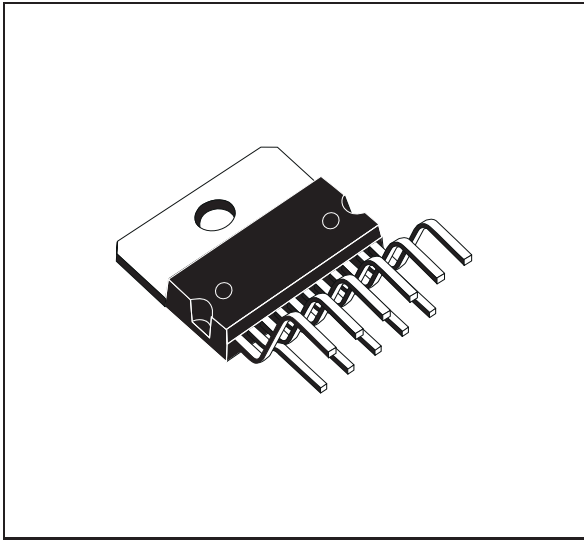

Figure 17: Thermal Protection & Diagnostic Waveforms



DIM.	mm			inch		
	MIN.	TYP.	MAX.	MIN.	TYP.	MAX.
A			5			0.197
B			2.65			0.104
C			1.6			0.063
D		1			0.039	
E	0.49		0.55	0.019		0.022
F	0.88		0.95	0.035		0.037
G	1.45	1.7	1.95	0.057	0.067	0.077
G1	16.75	17	17.25	0.659	0.669	0.679
H1	19.6			0.772		
H2			20.2			0.795
L	21.9	22.2	22.5	0.862	0.874	0.886
L1	21.7	22.1	22.5	0.854	0.87	0.886
L2	17.4		18.1	0.685		0.713
L3	17.25	17.5	17.75	0.679	0.689	0.699
L4	10.3	10.7	10.9	0.406	0.421	0.429
L7	2.65		2.9	0.104		0.114
M	4.25	4.55	4.85	0.167	0.179	0.191
M1	4.73	5.08	5.43	0.186	0.200	0.214
S	1.9		2.6	0.075		0.102
S1	1.9		2.6	0.075		0.102
Dia1	3.65		3.85	0.144		0.152

OUTLINE AND MECHANICAL DATA



Multiwatt11 V

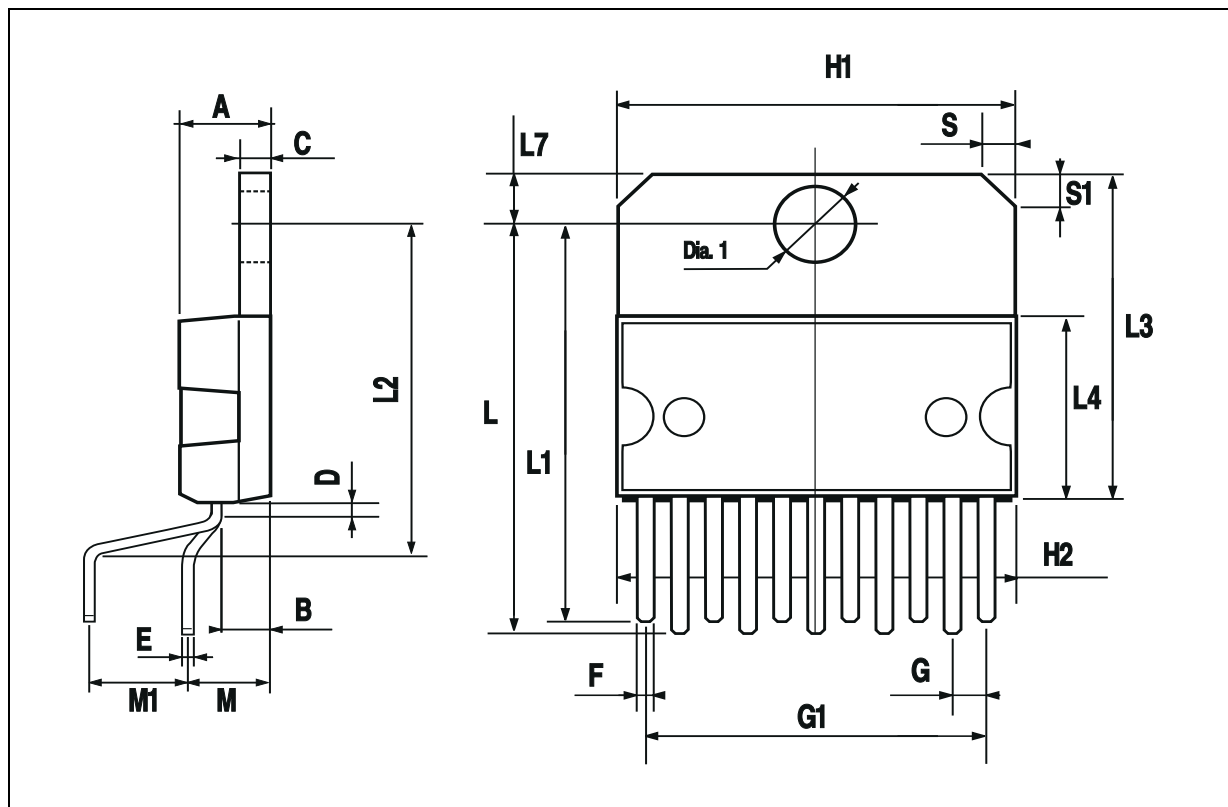

Information furnished is believed to be accurate and reliable. However, STMicroelectronics assumes no responsibility for the consequences of use of such information nor for any infringement of patents or other rights of third parties which may result from its use. No license is granted by implication or otherwise under any patent or patent rights of STMicroelectronics. Specification mentioned in this publication are subject to change without notice. This publication supersedes and replaces all information previously supplied. STMicroelectronics products are not authorized for use as critical components in life support devices or systems without express written approval of STMicroelectronics.

The ST logo is a registered trademark of STMicroelectronics
© 2002 STMicroelectronics – Printed in Italy – All Rights Reserved
STMicroelectronics GROUP OF COMPANIES

Australia - Brazil - Canada - China - Finland - France - Germany - Hong Kong - India - Israel - Italy - Japan - Malaysia - Malta - Morocco -
Singapore - Spain - Sweden - Switzerland - United Kingdom - United States.

<http://www.st.com>